

Monosplit a Cassetta



Caratteristiche

■ optional ■ standard



Telecomando



Funzione AutoRestart



Digital Tube Display



Aletta in alluminio idrofilo



Filtri lavabili



Fast Cooling Fast Heating



Raffreddamento a basse temperature



Quadro elettrico e morsettiera ignifughi



Pompa scarico condensa



Immissione Aria Esterna



Comando Centralizzato



Comando a Filo



Golden Fin



Controllo WIFI

Monosplit a Cassetta



Standard



Optional



Pompa scarico condensa

La pompa scarico condensa integrata può superare un dislivello di 1200mm dal livello della vaschetta

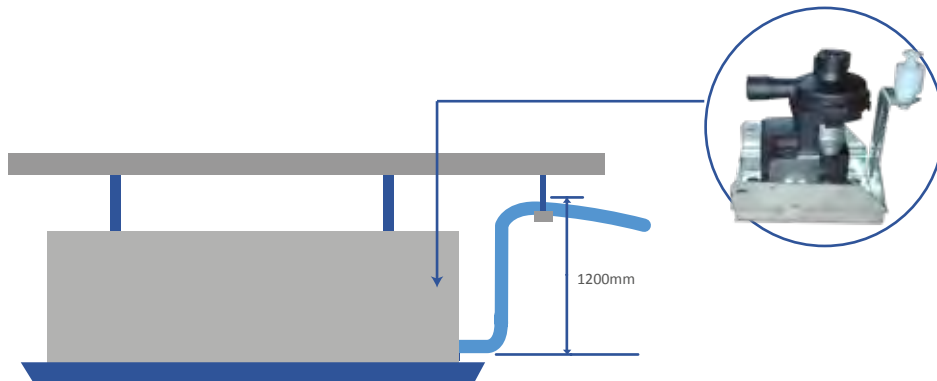

Presa aria di rinnovo*

La presa d'aria di rinnovo dell'unità interna rende l'aria più salubre e confortevole



Presa aria di rinnovo

Scatola elettrica ottimizzata

Migliore resistenza al fuoco e facile manutenzione



* sui modelli 24-36-42-48-60



Monosplit a cassetta

Unità Esterna		AL-H12/ NDR3H(U)	AL-H18/ NDR3H(U)	AL-H24/ NDR3HYB	AL-H36/ NDR3HYB	AL-H42/ NDR3HYB	AL-H48/ NDR3HYB	AL-H60/ NDR3HYB	
Unità Interna		ALCA-H12/ NDR3HAA	ALCA-H18/ NDR3HAA	ALCA-H24/ NDR3HAA	ALCA-H36/ NDR3HAA	ALCA-H42/ NDR3HAA	ALCA-H48/ NDR3HAA	ALCA-H60/ NDR3HAA	
ALIMENTAZIONE									
Tipo di Alimentazione	V/Nr.Fasi/HZ	230/2/50					400/3/50		
RAFFREDDAMENTO									
Resa Nominale	Btu/h	12000(4600-15000)	18000(5220-19100)	24000(7400-28000)	36000(9900-41000)	47399(10638-49786)	46400(16224-49761)	53600(16400-57000)	
Resa Nominale	kW	3,60(1.35-4,40)	5,30(1.53-5,60)	7,10(2.16-8,20)	10,95(2,9-12,0)	13,9(3,12-14,6)	14(4,76-16,5)	16(4,76-17,5)	
Potenza Assorbita	kW	1,08(0,26-1,60)	1,63(0,47-2,30)	2,18(0,67-3,56)	3,40(0,71-4,71)	4,5(0,8-5,39)	5,20(1,71-6,7)	5,71(1,38-6,85)	
SEER	W/W	6,2	6,3	6,6	6,1	6,2	6,2	6,2	
ERP Classe Energetica		A++	A++	A++	A++	A++	A++	A++	
EER	W/W	3,33	3,25	3,26	3,22	3,09	2,69	2,62	
RISCALDAMENTO									
Resa Nominale	Btu/h	14300(4200-18100)	19700(4800-21200)	27300(6800-31800)	38000(8800-46700)	51730(9956-55753)	52200(12900-55090)	60000(16700-63100)	
Resa Nominale	kW	4,60(1,24-5,30)	6,48(1,40-6,80)	8,00(1,98-9,30)	12,84(2,6-13,7)	15,2(2,92-16,35)	16(4,78-16,15)	17,00(4,90-18,50)	
Potenza Assorbita	kW	1,23(0,19-1,51)	1,73(0,46-2,25)	2,10(0,65-3,62)	3,45(0,47-4,13)	4,6(0,58-4,90)	5,4(1,71-6,8)	5,80(0,98-6,00)	
SCOP	W/W	4,1	4,0	4,5	4,0	4,0	4,1	4,0	
ERP Classe Energetica		A+	A+	A+	A+	A+	A+	A+	
COP	W/W	3,74	3,75	3,81	3,72	3,30	2,96	2,93	
Limiti Operativi	C°	Raffreddamento da -15°C a 52°C / Riscaldamento da -15°C a 24°C							
Caratteristiche Unità Interna		ALCA-H12/ NDR3HAA	ALCA-H18/ NDR3HAA	ALCA-H24/ NDR3HAA	ALCA-H36/ NDR3HAA	ALCA-H42/ NDR3HAA	ALCA-H48/ NDR3HAA	ALCA-H60/ NDR3HAA	
Portata aria	m3/h	700/600/530	700/600/530	1500/1350/1200	1950/1700/1600	2000/1700/1600	2000/1700/1600	2000/1700/1600	
Livello Pressione Sonora	dB(A)	45/44/36	45/44/36	47/43/38	51/48/45	51/48/45	53/48/42	53/48/42	
Livello Potenza Sonora	dB(A)	56	56	57	62	62	63	63	
Dimensioni(L×P×H)									
Unità Interna	mm	570×570×260	570×570×260	840×840×246	840×840×288	840×840×288	840×840×288	840×840×288	
Unità Interna Imballata	mm	655×655×295	655×655×295	910×910×310	910×910×350	910×910×350	910×910×350	910×910×350	
Cornice	mm	650×650×55	650×650×55	950×950×55	950×950×55	950×950×55	950×950×55	950×950×55	
Cornice Imballata	mm	710×710×80	710×710×80	1000×1000×100	1000×1000×100	1000×1000×100	1000×1000×100	1000×1000×100	
Peso Unità	kg	17	17	26	28	30	30	30	
Peso Unità imballata	kg	20	20	30	33	35	35	35	
Peso Cornice	kg	2,2	2,2	5,3	5,3	5,3	5,3	5,3	
Peso Cornice imballata	kg	3,7	3,7	7,8	7,8	7,8	7,8	7,8	
Diametro Scarico condensa	mm(inch)	DN20(R3/4)	DN20(R3/4)	DN20(R3/4)	DN20(R3/4)	DN20(R3/4)	DN20(R3/4)	DN20(R3/4)	
Caratteristiche Unità Esterna		AL-H12/ NDR3A(U)	AL-H18/ NDR3A(U)	AL-H24/ NDR3A(U)	AL-H36/ NDR3A(U)	AL-H42/ NDR3A(U)	AL-H48/ NDR3A(U)	AL-H60/ NDR3A(U)	
Portata aria	m3/h	2600	2600	3750	4000	4200	7200	7200	
Livello Pressione Sonora	dB(A)	54	55	58	57	57	60	60	
Livello Potenza Sonora	dB(A)	63	64	66	66	66	70	70	
Dimensioni(L×P×H)									
Unità	mm	800×315×545	800×315×545	900×350×700	970×395×805	970×395×805	940×370×1325	940×370×1325	
Unità Imballata	mm	920×400×620	920×400×620	1020×430×770	1105×495×895	1105×495×895	1080×430×1440	1080×430×1440	
Peso Unità	Kg	35	37	51	72	72	92	92	
Peso Unità Imballata	Kg	38	40	55	76	76	108	108	
Linee Frigorifere									
Linea Liquido	mm(inch)	6.35(1/4)	6.35(1/4)	9.52(3/8)	9.52(3/8)	9.52(3/8)	9.52(3/8)	9.52(3/8)	
Linea Gas	mm(inch)	12.7(1/2)	12.7(1/2)	15.88(5/8)	15.88(5/8)	15.88(5/8)	19.05(3/4)	19.05(3/4)	
Lunghezza Massima	m	25	30	50	65	65	65	65	
Dislivello Massimo	m	10	20	25	30	30	30	30	

* Nota: I dati tecnici e dimensionali sopra riportati sono soggetti a modifiche senza preavviso. Fare sempre riferimento alle specifiche tecniche fornite dalla casa madre o dal distributore esclusivo.

AUX

Tecnology Leads Intelligent Life

AUX
AIR CONDITIONER

CAELI Srl

Via BorgoNuovo 7 20121 Milano
Via Pietro Generali 68 28100 Novara
Tel. 0321 1930110
info@caelisrl.com - www.auxclima.it